

CTS7F

General

The CTS (= continuous traction system) allows a shifting without using the clutch and without changing the throttle position, but with using ignition cut-offs instead. Shifting with ignition cut-offs requires the engine to be in traction mode, because an ignition cut-off cannot achieve the required torque difference while coasting.

A sensor in the gear shift lever or gear shift linkage triggers, at a certain force, the ignition cut-off. Due to the fast torque difference, the current gear is taken out, and, with keeping the gear shift lever pressed, the next gear is engaged.

With CTS, faster accelerations are achieved, the shifting process is smoother, and the timing during shifting is optimized (because only one lever must be pressed).

The CTS consists of an electronic box (= CTS box) and of two sensors. The first sensor is a force sensor, which triggers when the ignition should be cut-off. The second sensor, a position sensor, detects the mechanical progress of the shifting process (e. g. by detecting the rotation angle of the selector drum), and determines when to end the ignition cut-off.

Optionally, a gear shift flash lamp can be connected to the CTS box, which flashes at an adjustable engine speed.

Driving with CTS

The best results for driving with CTS are obtained, if the the throttle position is kept steady during the shifting. It does not matter whether the half throttle position or the full throttle position is kept. The gear shift lever should be pressed fully and kept in this position until the ignition cut-off is finished.

It should be avoided to tip the gear shift lever tentatively, because the ignition cut-off will then be initiated, but due to the missing end signal, the ignition cut-off time will be maximal. Thus, the gear shift lever should be pressed as long as the traction force is present again.

CTS Box

The CTS box is only suitable for motorbikes with a transistor ignition with up to 4 cylinders (or up to 8 cylinders for the CTS7Z8 box). Having one pin of the ignition coil connected to +12 V is an indicator for a transistor ignition. For Suzuki motorbikes, an additional *power unit* is required, to prevent the vehicle's monitoring system to wrongly detect an error code during a CTS ignition cut-off. The CTS box version CTS7N2 is for motorbikes with multiple ignition coils, e. g. BMW flat twin engine.

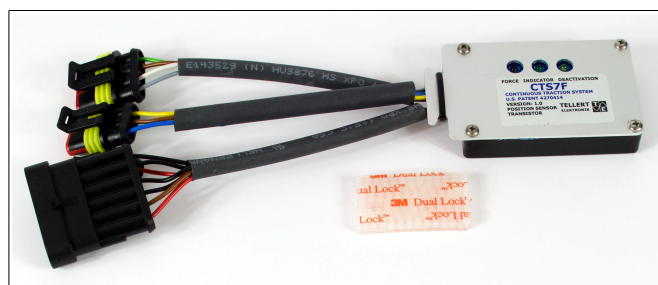

Figure 1: CTS7F box.

LEDs (CTS Box)

The CTS box has three LEDs which show the current state of the box:

Indicator (green): Continuous or blinking light means that the CTS box is connected to power, and that its microcontroller is running. The blinking frequency is proportional to the engine speed. The continuous or blinking light will be turned off during an ignition cut-off. After turning the ignition on, and as long as the engine has not been started, this LED shows the position of the position sensor:

1. **Continuous light:** The gear shift lever is not used and in idle position. The sensor voltage is greater than 3.5 V.
2. **Fast blinking:** The pawls are in pawl-on-pawl position, and the next gear cannot engage now. The sensor voltage lies within the range from 2.5 V to 3.5 V.
3. **No light (for older firmware versions only):** The pawls are partially in contact but the end stop is not yet reached. The sensor voltage lies within the range from 1 V to 2 V.
4. **Slow blinking (or continuous light for even older firmware versions):** The pawls are completely in contact (end stop position). The light of the slow blinking cycle is on for 75 % of the time, and off for 25 % of the time. The sensor voltage is less than 0.8 V.

Force (red): This LED shows the state of the force sensor. As soon as the gear shift lever is pressed with the minimal force, the red LED glows and an ignition cut-off is triggered.

Deactivation (yellow): As long as this (yellow) LED glows, no ignition cut-off will be triggered.

Force Sensor

The force sensor can be disassembled in its pieces. And, depending on the assembling, either a pressure sensor or a stretch sensor is obtained.

Usually, the force sensor does not readjust itself. However, its correct functioning can be verified as following:

1. Turn the CTS box on (or provide the CTS box with power).
2. As soon as the force sensor triggers, the red “force” (or “start”) LED lights up.

Gear shift lever sensor as force sensor replacement: For certain motorcycle types, it is not possible to install the force sensor, because of e. g. missing rods. In this case, a gear shift lever sensor can be used, instead of a force sensor. A gear shift lever sensor has the same functionality as a force sensor, but it is mechanically built differently, and needs no adjustment.

Further information to the force sensor can be found in Appendix 1.

Position Sensor

The position sensor detects three different positions (or four different positions for older firmware versions). The correct functioning of the position sensor can be verified with the LED of the CTS box (or with an optional available gear shift flash lamp).

Further information to the position sensor can be found in Appendix 2.

Gear Shift Flash Lamp

Starting with firmware version 7.0, it is possible to control an optional available gear shift flash lamp with a CTS5TW, CTS7 or CTS7F box. The gear shift flash lamp settings can be changed with a PC software.

The gear shift flash lamp should be as bright that it is perceivable even if the focus is on the street during sunlight. The new version of the gear shift flash lamp has eight white LEDs and has approximately the same brightness as the former gear shift flash GSF4.

During flashing the firmware, the settings are taken from a configuration file. These settings can be changed, e. g. to turn on a single flash / twin flashes (consisting of a main flash and an auxiliary/learn flash) / rev limiter flash.

With ignition turned on, and as long as the engine is not running, the gear shift flash lamp shows the following sensor states:

1. As soon as the force sensor triggers, a short flash for 0.1 s is displayed.
2. As soon as the position sensor detects the *pawl-on-pawl* position, the fast blinking of the green LED will be used for the gear shift flash lamp as well.
3. As soon as the gear is changed completely, and the gear shift lever is in *end stop* position, the slow blinking of the green LED (according to the firmware age) will be used for the gear shift flash lamp as well.

The CTS box CTS7F already provides the power supply to the gear shift flash lamp with a 1-pin AMP socket. This wire is identical to the CTS power supply (pin M1) but missing for older CTS boxes (CTS7, CTS5TW). However, this wire can be connected manually for upgrading older CTS boxes (CTS7, CTS5TW).



Figure 2: CTS7F box with gear shift flash lamp.

Pin Assignment (CTS Box)

The CTS box has three pigtails which are connected to the motorbike. The pigtails have either plugs or sockets with following pin assignment:

6-pin plug:

Pin	Wire color	Connection	CTS harness
M1	red	Protected +12 V power supply for ignition behind the fuse box	red
M2	brown	Ground	brown
M3	black	Clamp 1 of an ignition coil	black
M4	black	Clamp 1 of an ignition coil	orange
M5	black	Clamp 1 of an ignition coil	yellow
M6	black	Clamp 1 of an ignition coil	green

4-pin position sensor socket:

Pin	Wire color	Description	Sensor wire color ¹
R1	green	Power supply (+5 V) for the Hall effect sensor elements	white (prev.: red)
R2	brown	Ground	brown
R3	white	Position sensor signal	green (prev.: black)
R4	gray	Signal for CTS off-switch (For deactivating the CTS box, connect this pin to ground)	

3-pin force sensor socket:

Pin	Wire color	Description	Sensor wire color ¹
S1	yellow	Power supply (+5 V) for the force sensor	white (prev.: red)
S2	brown	Ground	brown
S3	blue	Force sensor signal	green (prev.: black)

1-pin socket for power supply of the gear shift flash lamp:

Pin	Wire color	Description
G1	red	Power supply (+12 V)

1 The sensor wire color has changed from [red/brown/black] to [white/brown/green]

CTS for Suzuki motorbikes

For Suzuki motorbikes, an additional box, the power unit (= SPU), is required beside the CTS box. The SPU prevents the vehicle's monitoring system from detecting an error code.

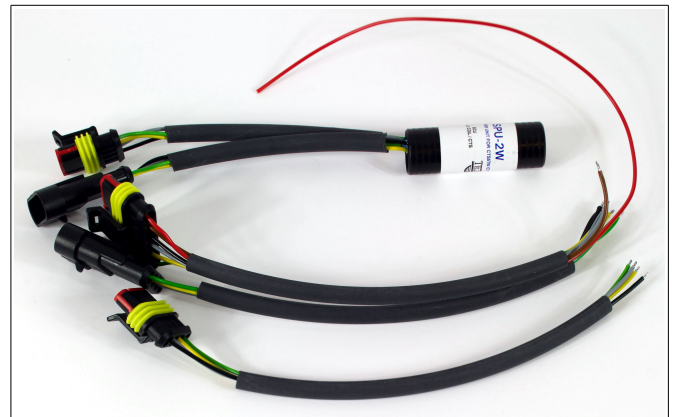

Figure 3: SPU with wire harness.

To install the power unit, each wire between ignition coil and ECU must be cut, and the newly created wire ends must be connected with the corresponding power unit pins (the one wire end, belonging to the ECU, is connected to PA1, and the other wire end, belonging to the ignition coil, is connected to PB1, and correspondingly for the remaining cut wires, the wire ends are connected to PA2/PB2, PA3/PB3 and PA4/PB4). Furthermore, it will be assumed, that Suzuki motorbikes are shipped with 2 gray plugs, at which one connector is numbered from 1 bis 34, and the other one is numbered from 35 bis 68.

4-pin power unit plug A:

Pin	Wire color	Connection (depending on vehicle type)	Suzuki ECU harness
PA1	black	ECU pin 16 50 11	black
PA2	gray	ECU pin 17 51 12	white/blue
PA3	yellow	ECU pin 15 49 24	yellow
PA4	green	ECU pin 34 68 36	green

4-pin power unit socket B:

Pin	Wire color	Connection
PB1	black	If PA1 is connected: CTS box pin M3 and clamp 1 of ignition coil belonging to PA1
PB2	gray	If PA2 is connected: CTS box pin M4 and clamp 1 of ignition coil belonging to PA2
PB3	yellow	If PA3 is connected: CTS box pin M5 and clamp 1 of ignition coil belonging to PA3
PB4	green	If PA4 is connected: CTS box pin M6 und clamp 1 of ignition coil belonging to PA4

6-pin plug for CTS with power unit:

Pin	Wire color	Connection (depending on vehicle type)	CTS harness
M1	red	Protected +12 V power supply for ignition behind the fuse box (orange/yellow wire)	red
M2	brown	Ground: ECU pin 33 67 (black/white wire)	brown
M3	black	If PA1 is connected: SPU pin PB1 and clamp 1 of ignition coil belonging to PA1	black
M4	black	If PA2 is connected: SPU pin PB2 and clamp 1 of ignition coil belonging to PA2	gray
M5	black	If PA3 is connected: SPU pin PB3 and clamp 1 of ignition coil belonging to PA3	yellow
M6	black	If PA4 is connected: SPU pin PB4 and clamp 1 of ignition coil belonging to PA4	green

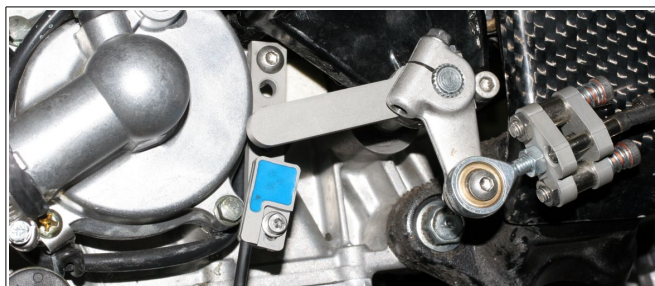

Figure 5: Arrangement of older position sensor and magnet lever.

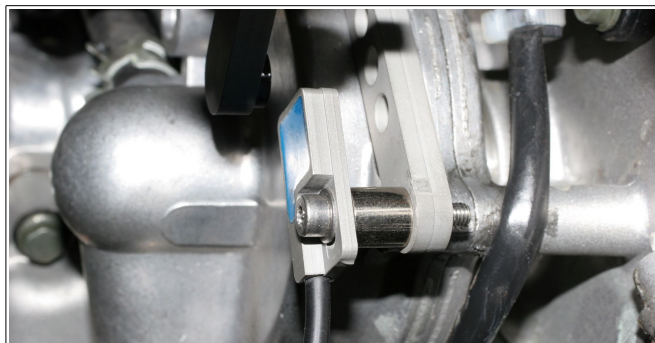

Figure 6: Older position sensor with distance piece.

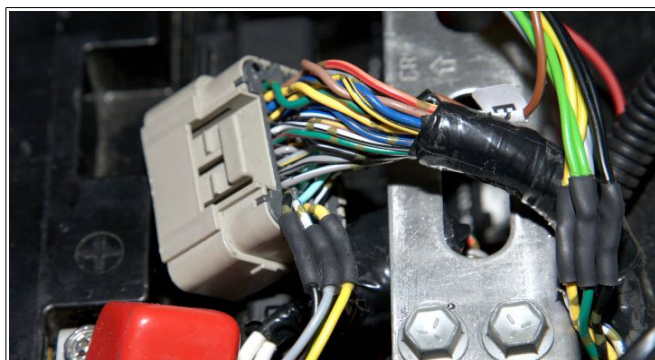

Figure 7: CTS connection with the ECU connector 1/3.

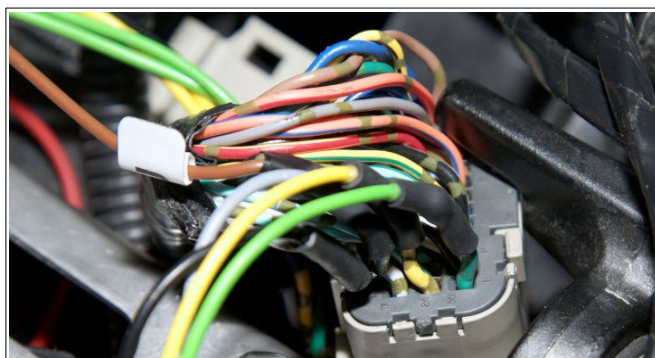

Figure 8: CTS connection with the ECU connector 2/3.

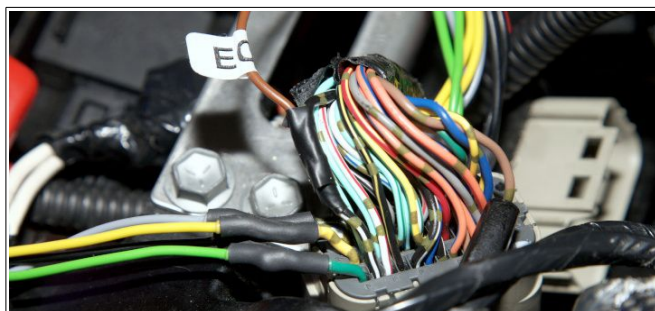

Figure 9: CTS connection with the ECU connector 3/3.

Example Images

The following images show the installation of the CTS with power unit in a Suzuki with bottom gear shift lever shaft.

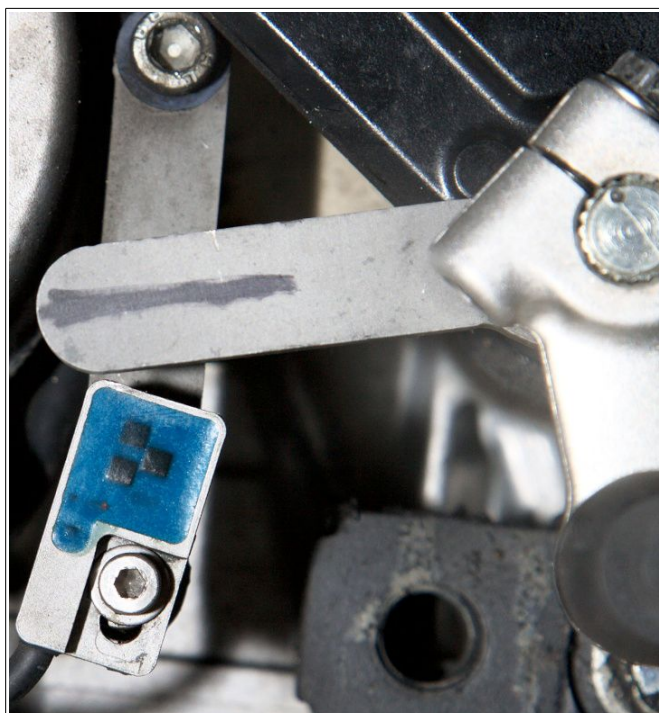

Figure 4: Older position sensor in idle position.

Troubleshooting

If shifting under high load is impossible, than it may be possible that not all ignition coils are connected to the CTS. In this case, with disconnected ignition, the 6-pin plug can be disconnected from the CTS box, and the ohmic resistance of the respective ignition coils can be measured with an ohmmeter: If installed correctly, then a typical coil resistance within the range from 1 Ω to 3 Ω (= primary winding resistance) must be measured between the pin M1 (red wire) and pin M3, M4, M5 or M6. The resistance is dependent on the vehicle type and the coil temperature, but it should be approximately equal among each other (M1 – M3, M1 – M4, M1 – M5 and M1 – M6), and approximately twice as much if two coils are measured concurrently (M3 – M4, M3 – M5, M3 – M6, M4 – M5, M4 – M6, M5 – M6).



Figure 10: Measurement of the ignition coil resistance.

A (noticeable) ignition cut-off will only then be triggered, if the force sensor signals under load, and the position sensor is in the range of the *idle* position at the same time. If the position sensor has a shortcut, the position sensor always identifies the *end stop* position, and no ignition cut-off will be triggered.

If the position sensor is disconnected, then the CTS box runs only in an emergency operation mode. This emergency operation should only be used for test purposes or during a race, to upshift within the high engine speed range, because a possible gearbox damage can not be excluded. The typical cut-off time during the emergency operation is reduced to about 60 ms, and does not allow a shifting within the low engine speed range.

If the engine does not run properly, then the CTS can be temporarily removed entirely from the vehicle electricity. For this purpose, only the 6-pin plug of the CTS box must be disconnected, and additionally only for Suzuki motorbikes with power unit, the SPU must be disconnected, and both released 4-pin connectors of the harness must be connected with each other. Subsequently, if the engine does not run properly, the CTS can be excluded from the troubleshooting, because the CTS does not now interfere with the vehicle electricity.

Versions of the CTS Boxes

CTS7F

- The CTS7F box has (in parallel to the 6-pin plug) an additional wire with a 1-pin socket to supply a gear shift flash lamp.

CTS7

- Smaller box dimensions than CTS5TW (the electronic box has a smaller height).
- The CTS7 box does work reliably even for a Honda Fireblade SC59 in the part-load operational range.
- The engine speed measurement is more precise by using an earlier trigger time.
- Due to the more precise engine speed measurement, the CTS7 box has, in certain circumstances, a problem with debouncing the engine speed signal for motorbikes with multiple ignition coils per cylinder (e. g. BMW flat twin engine). This problem is solved with CTS box CTS7N2.
- Different labeling, different LED colors:

CTS7F/CTS7	CTS5TW/CTS5BMW
Yellow LED (Deactivation)	Green LED (Disable)
Text: Force	Text: Start
Text: Indicator	Text: Func.
Text: Deactivation	Text: Disable

CTS7N2

- Special version of the CTS7 box for motorbikes with multiple ignition coils per cylinder: Only pin M3 and pin M4 are used for both the main ignition coils and the engine speed measurement. Pin M5 and pin M6 are only used for the auxiliary ignition coils.

CTS7Z8

- Special version of the CTS7 box for automotive applications with support for up to eight ignition coils with symmetric firing order.

CTS5TW

- CTS with position sensor. The electronic box CTS5TW is identical to the electronic box CTS5BMW.

CTS5BMW

- CTS for BMW K1200 without position sensor (the built-in selector drum pot is used instead).
- Two wires (gray and white) of the 4-pin socket are possibly interchanged for older CTS5BMW boxes in comparison to CTS5TW boxes.

Internet

Further information for CTS7 (like e. g. the most recent

firmware) are available in the Internet at:

<http://www.tellert.de/?product=cts7>

Connection Plans

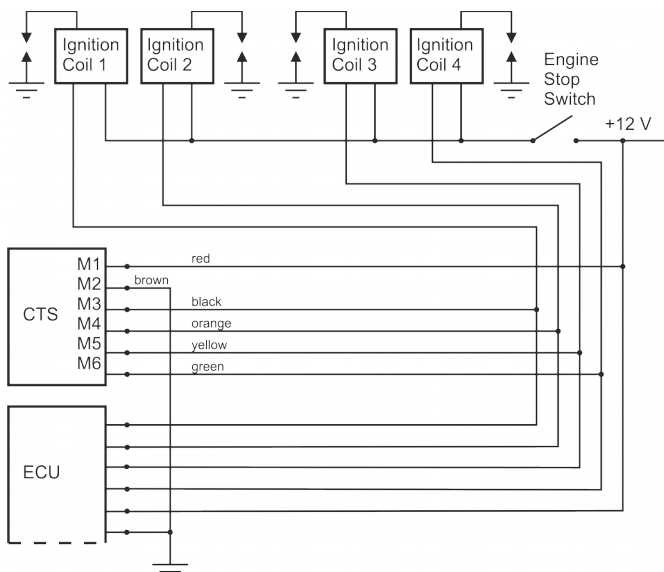

Figure 11: General CTS connection plan without power unit.

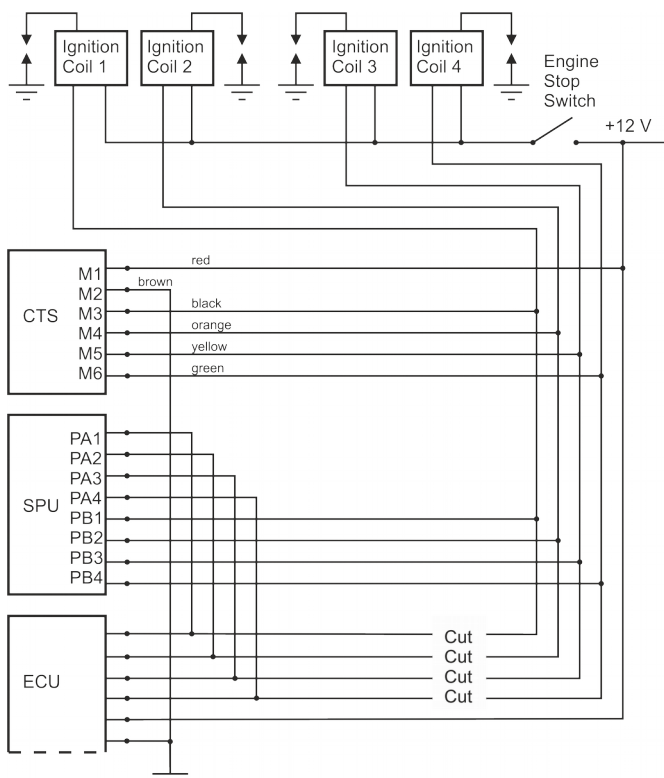

Figure 12: General CTS connection plan for Suzuki with power unit.

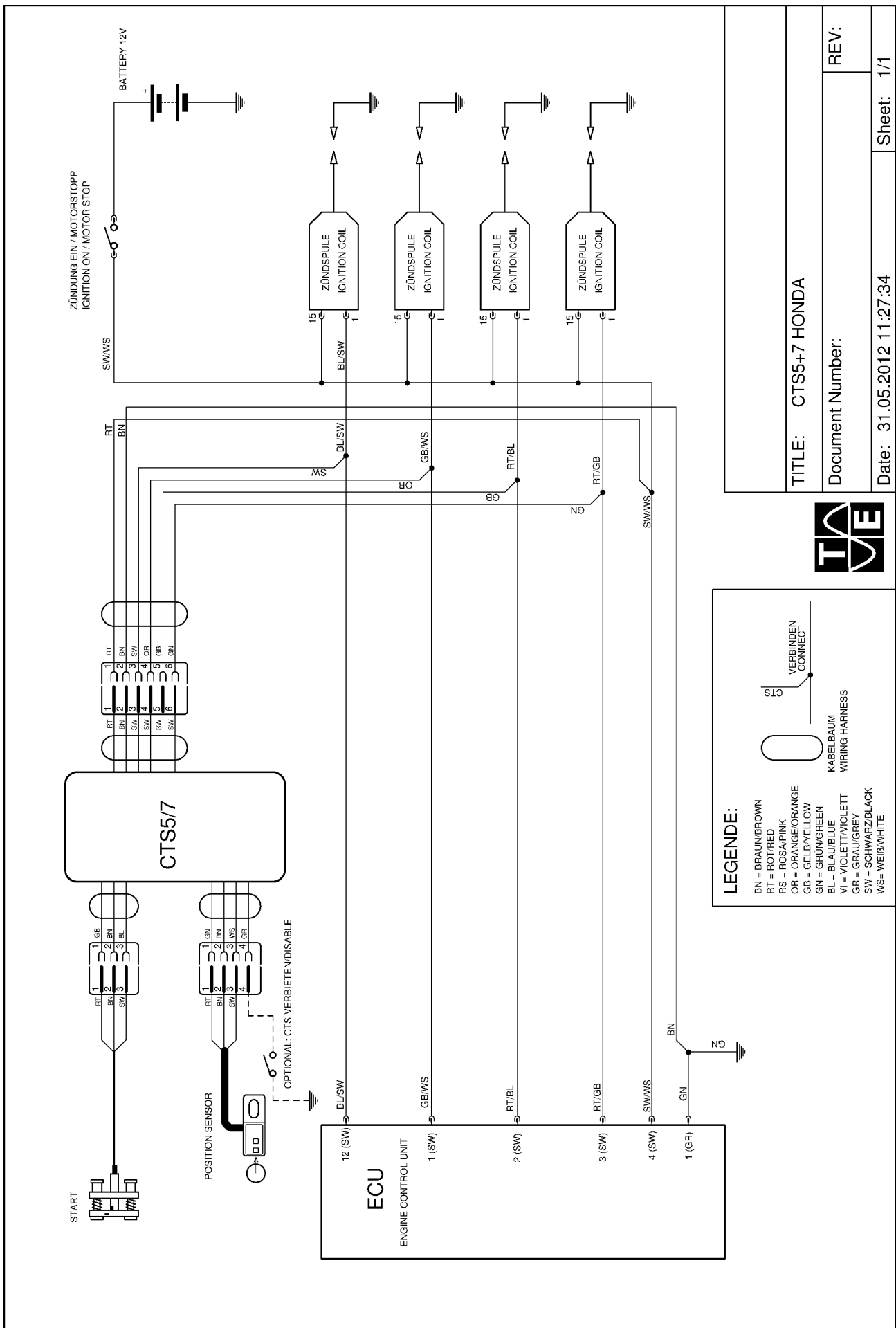

Figure 13: CTS connection plan for Honda.

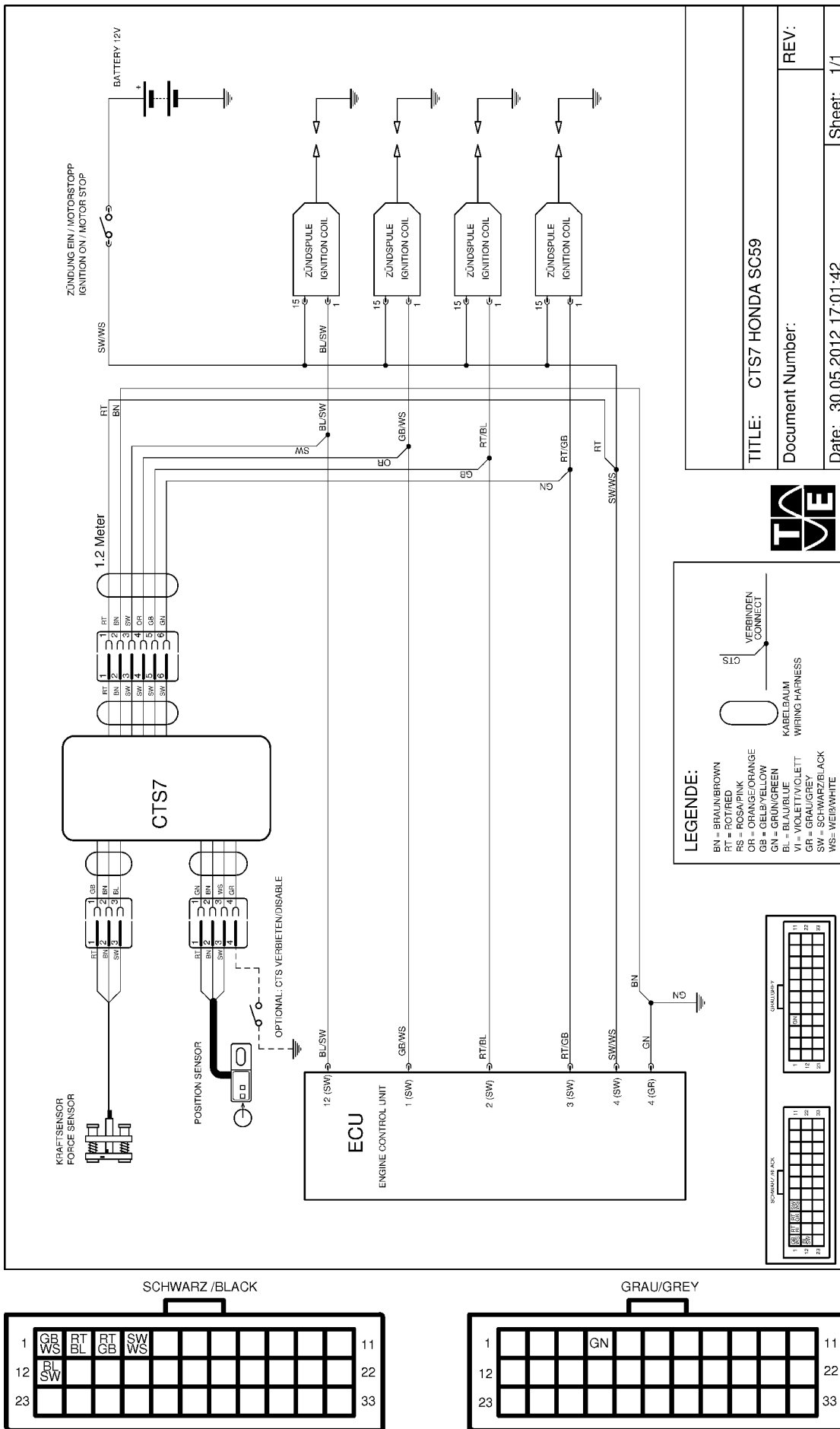

Figure 14: CTS connection plan for Honda SC59.

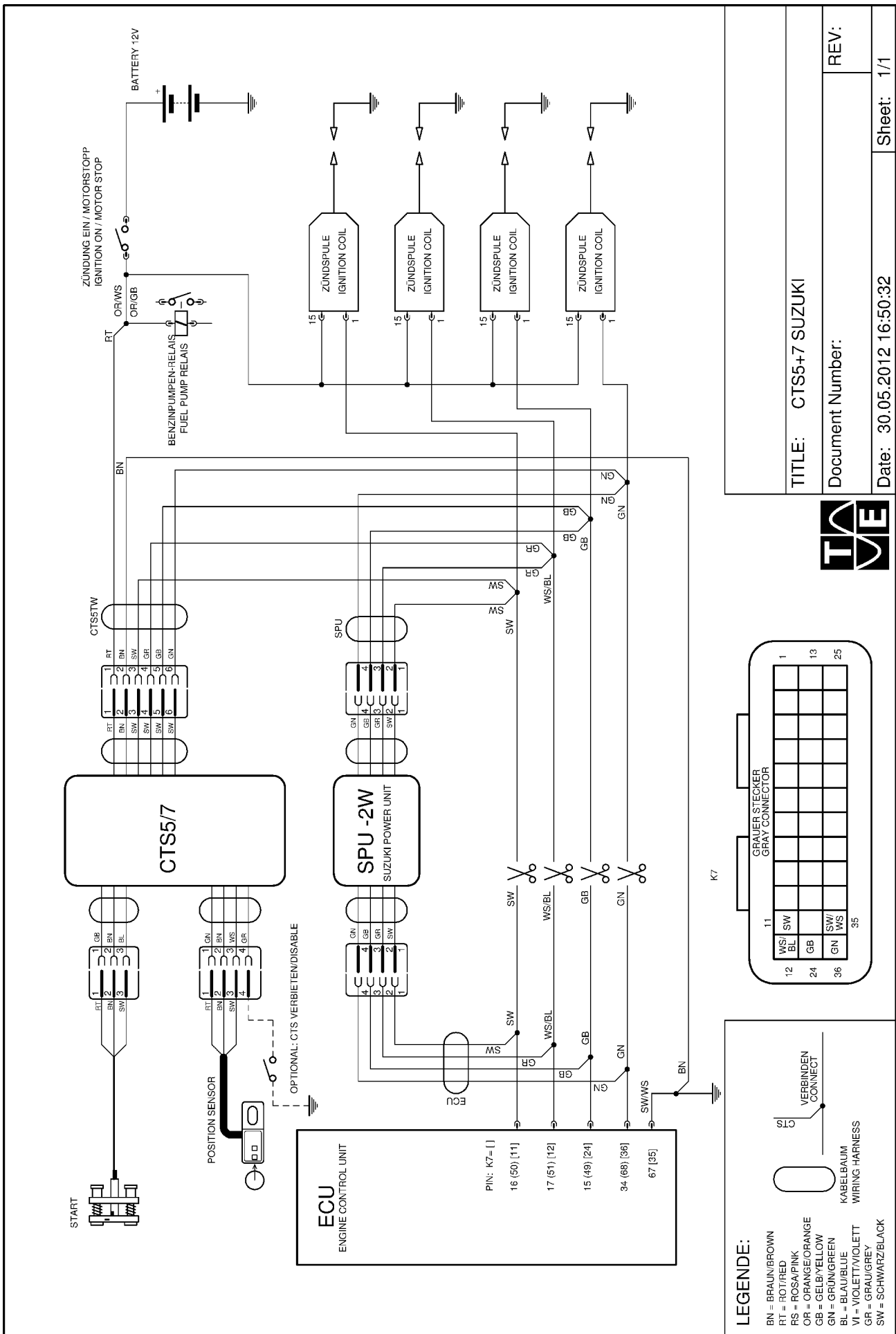
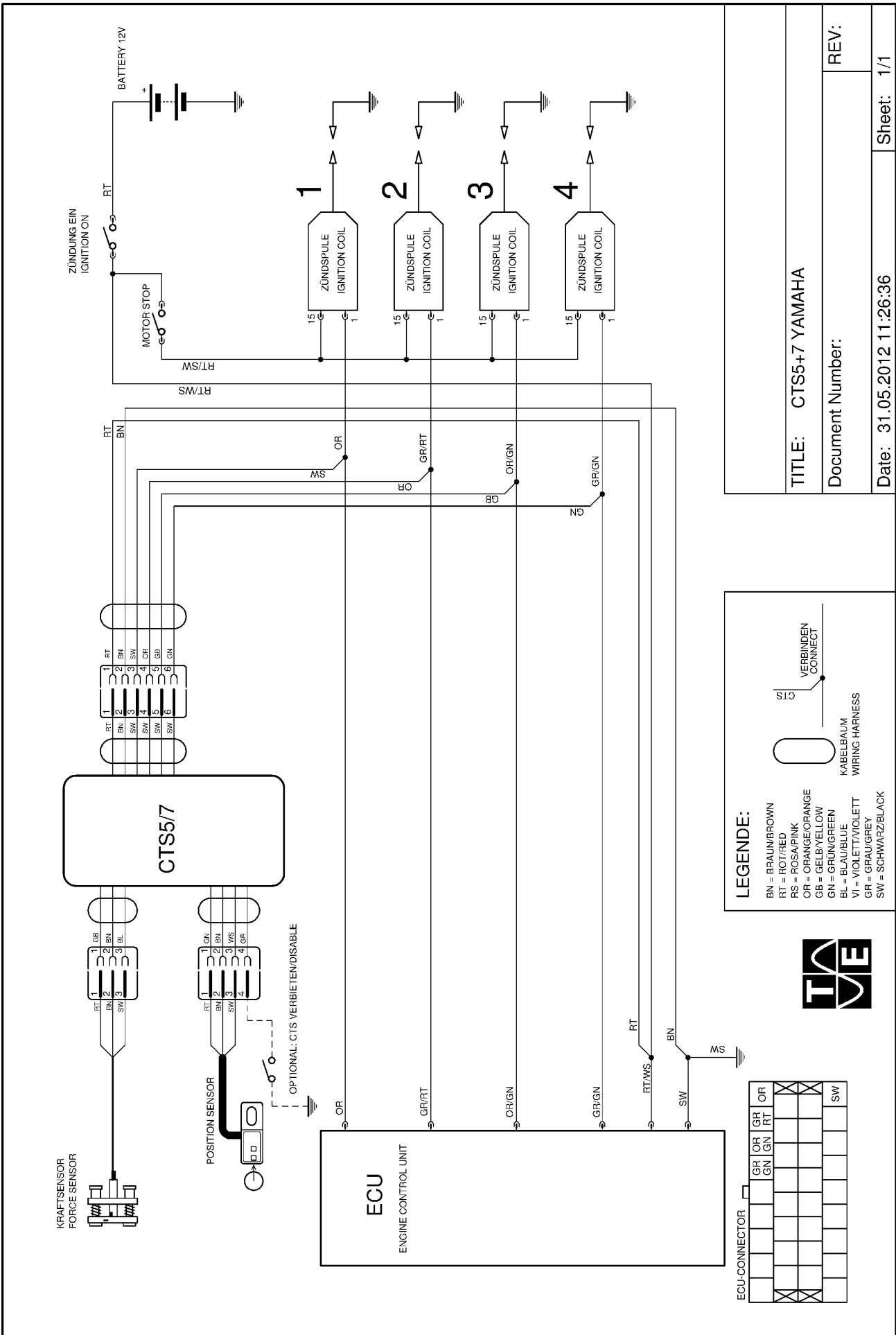

Figure 15: CTS connection plan for Suzuki with power unit.



TITLE: CTS5+7 YAMAHA
Document Number:
Date: 31.05.2012 11:26:36
Sheet: 1/1

LEGENDE:
 BN = BRAUN/BROWN
 RT = ROT/RED
 RS = ROSA/PINK
 OR = ORANGE/ORANGE
 GB = GELB/YELLOW
 GN = GRÜN/GREEN
 BL = BLAU/BLUE
 VI = VIOLETT/VIOLETT
 GR = GRAU/GREY
 SW = SCHWARZ/BLACK

VERBINDEN CONNECT
 CTS

KABELBAUM WIRING HARNESS



Figure 16: CTS connection plan for Yamaha.

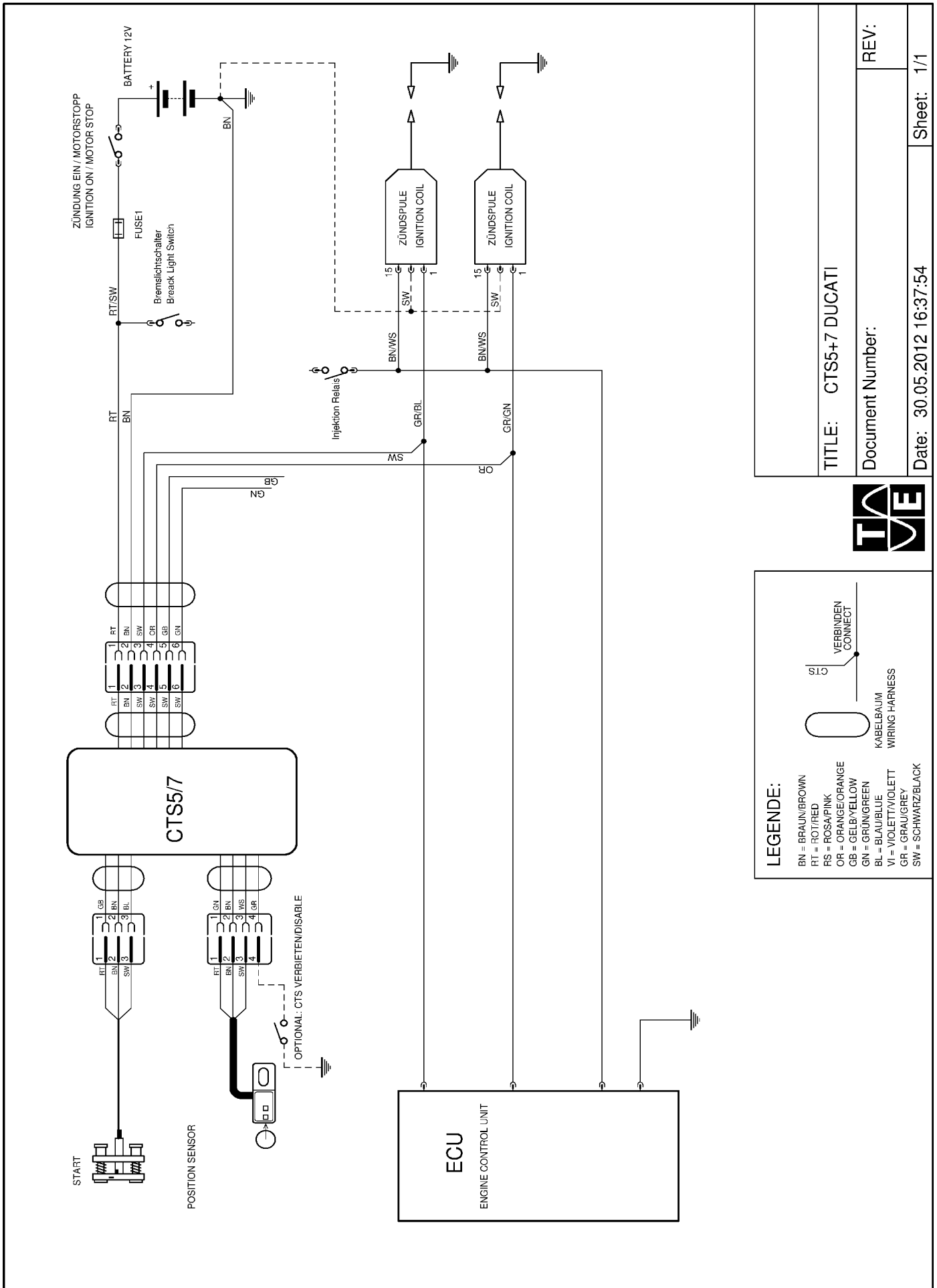

Figure 17: CTS connection plan for Ducati.

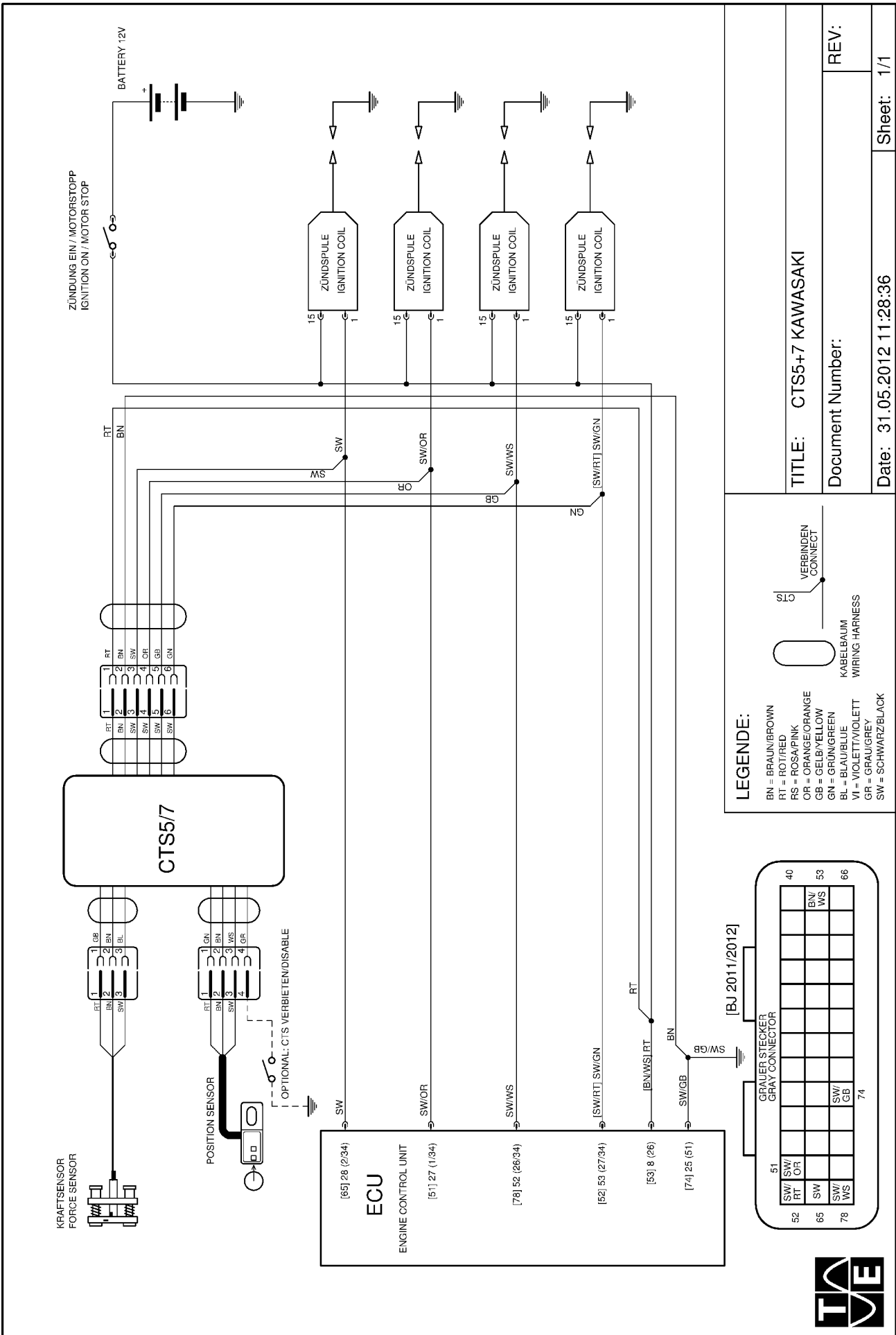

Figure 18: CTS connection plan for Kawasaki.

Appendix 1: Force Sensor

The force sensor measures the force which occurs during upshifting. It detects an adjustable minimal force, which is required to change a gear properly. As soon as this minimal force is reached, the red “force” (or “start”) LED of the CTS box lights up.

This minimal force should be greater than the force which is necessary to search for the neural position with running engine and drawn clutch.

The force sensor is designed to be installed within the gear shift linkage, and it has the following properties:

- The force sensor can be remodeled in either pressure or stretch direction.
- The Hall effect sensor for the signal generation is wearless and protected against vibrations and water.
- A narrow side with only 6 mm distance to the axis center allows an installation even if the gear shift linkage is close-fitting with the frame.
- All parts are individually deliverable.
- All surfaces are protected against corrosion.
- The signal threshold and the total distance (spring accumulator) is adjustable.
- The magnet plate is deliverable with a clockwise or anticlockwise (for Honda) screw thread M6.
- The force sensor is protected against twisting.

Force Sensor Adjustment

In practice the force sensor is adjusted in such a way, that it triggers at a gear shift lever force from 50 N to 100 N. Due to the lever transmission of the gear shift linkage, the force sensor usually experiences the 3-fold of the force which is applied to the gear shift lever. Therefore, the typical triggering sensor force lies within the range from 150 N to 300 N. The following information is helpful for the exact setting of the triggering sensor force: Both springs have together a spring constant of 64 N/mm (meaning 32 N/mm for each spring). The springs have a respective unstressed length of 12 mm. A single spring can be compressed to maximal 6 mm. The unstressed sensor presses each of the springs 2 mm to a resulting length of 10 mm (meaning a total spring pre-load of 128 N). By default, the Hall effect sensor is placed in such a way, that it triggers at a distance difference of 1 mm (meaning a triggering sensor force of 192 N). The spring pre-load, and thus the desired triggering sensor force, can also be adjusted by equally turning both guide screws (with each turn equates a spring travel of 1 mm, and thus an additional total spring pre-load of 64 N).

Remodeling of the Force Sensor

For remodeling the force sensor from pressure to stretch direction (or from stretch to pressure direction), the following steps have to be taken into account:



Figure 19: The force sensor is put together as pressure sensor. The springs are within the plates.



Figure 20: The Hall effect sensor is removed (with hexagonal socket wrench of wrench size 2).



Figure 21: The lock nuts are loosened and removed (wrench size 10).

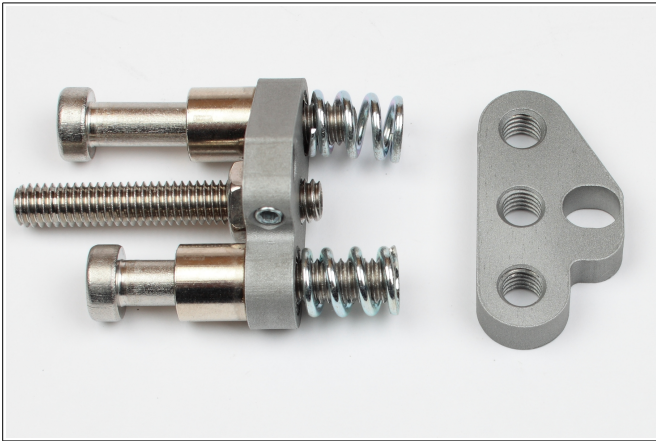

Figure 22: The screws are loosened (with hexagonal socket wrenches of wrench sizes 4 or 5).

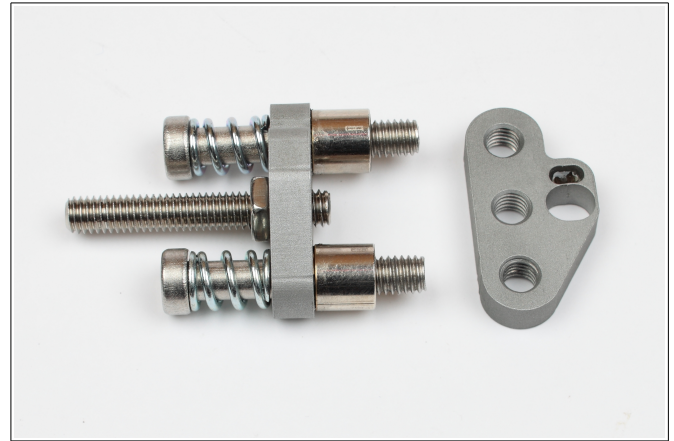

Figure 25: The springs are put on the screws.



Figure 23: The headless hexagonal socket screw M6x40 is removed.

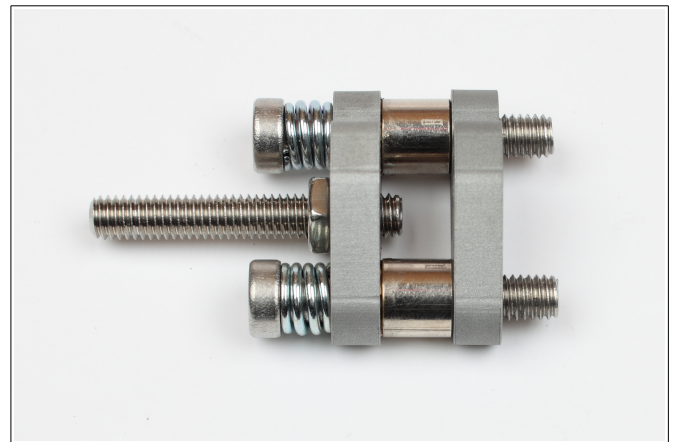

Figure 26: The magnet plate is tightened, until the springs blockade.

Note: The springs can be damaged, if the screws are too tight.



Figure 24: Both plates are turned, at which both the nuts and the magnet plate turn inwards. The headless hexagonal socket screw M6x40 is tightened.



Figure 27: The screws are loosened with 3 turns (M6 has a lead of 1 mm/turn), and then locked in this position with the lock nut.



Figure 28: The sensor is pre-loaded with 1 mm. For this purpose, M5 washers, which have a thickness of 1 mm, are suited.



Figure 29: The Hall effect sensor is adjusted (in regard of the minimal triggering force), at which the sensor should be pre-loaded with about 1 mm. With reaching the minimal triggering force, the “force” (or “start”) LED lights up.



Figure 30: Note that the black Hall effect sensor element faces the magnet. The Hall effect sensor element is the black part inside the nickel-plated sensor bushing. The magnet is glued in the the magnet plate.

Remodeling as pressure sensor: The Hall effect sensor is entirely put through, and then slowly pulled back, until the “force” (or “start”) LED lights up.

Remodeling as stretch sensor: The Hall effect sensor is slowly put through, until the “force” (or “start”) LED lights up.

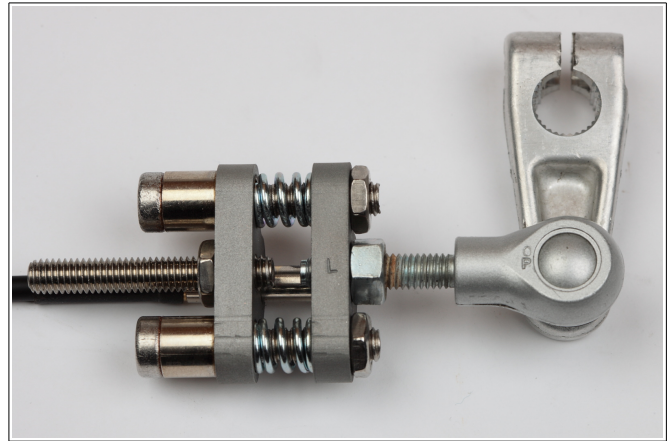

Figure 31: Magnet plate with left-handed thread M6.

For certain vehicle types (e. g. Honda SC57, SC59), there are magnet plates with left-handed thread M6, to bring the joint head as close as possible to the force sensor.

- As a marker, the letter *L* is imprinted on the magnet plate.
- The force sensor is maintenance-free. However, during the installation, it is recommended to coat the shanks of the screws M6x35 thinly with copper paste.
- For special purposes, weaker and stronger springs are available.
- The sensor shouldn't trigger during the search for the neutral position.

Attention: The connecting set screws (which are screwed in both plates) should not interfere with the sensor travel. The set screws may jut out up to 3 mm on each side beyond the inside of the plates.

Installation in the Rods

The original rod has to be shortened by 40 mm at the side with the right-handed thread.

Default Setting

By default, the force sensor is delivered as pressure sensor with a spring pre-load of 3 mm, and a Hall effect sensor trigger distance of about 1 mm.

Verification

The force sensor can be verified with the red “force” (or “start”) LED of the CTS box, or with the gear shift flash lamp.

The triggering force can be measured with a spring scale at the gear shift lever, at which the corresponding weight should lie within the range from 5 kg to 10 kg.

Appendix 2: Position Sensor

The position sensor detects the progress of the upshifting operation. Two sensor elements are used for this purpose. The position sensor is mounted at the crankcase, and a magnet, which is fixed onto a lever to the gear shift lever shaft, swings over the blue area of the position sensor. The distance between magnet and sensor should be less than 1.5 mm, at which the axial slackness of the gear shift lever shaft should not cause a contact of the magnet with the position sensor.

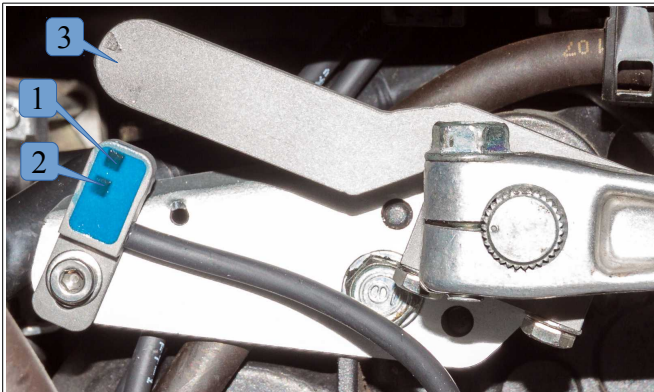

Figure 32: Honda SC59 with prev. position sensor and magnet lever.

1. Sensor element *pawl-on-pawl*
2. Sensor element *end stop*
3. Magnet (glued from behind)

The sensor elements are dependent on a magnetic field, and signal as soon as the edge of the magnet approximates the center of the respective sensor element to about 1.5 mm.

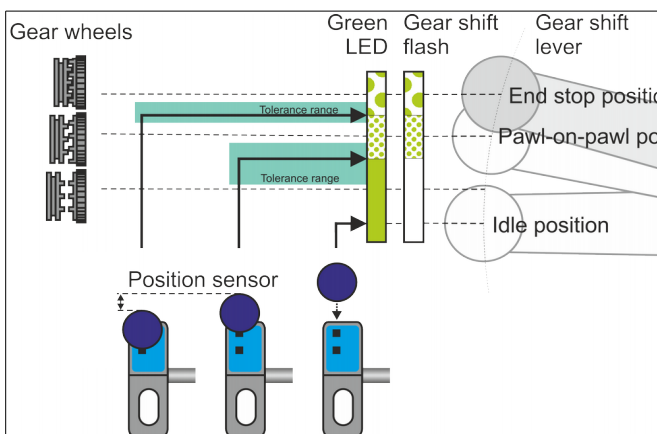

Figure 33: Positions of the position sensor.

For a correct functioning of the position sensor, it is important that the respective sensor elements signal in the right order. Therefore, while upshifting, the magnet has to approximate the position sensor with an angle from preferably 0° to maximal ±45° (see also green valid area of Figure 34).

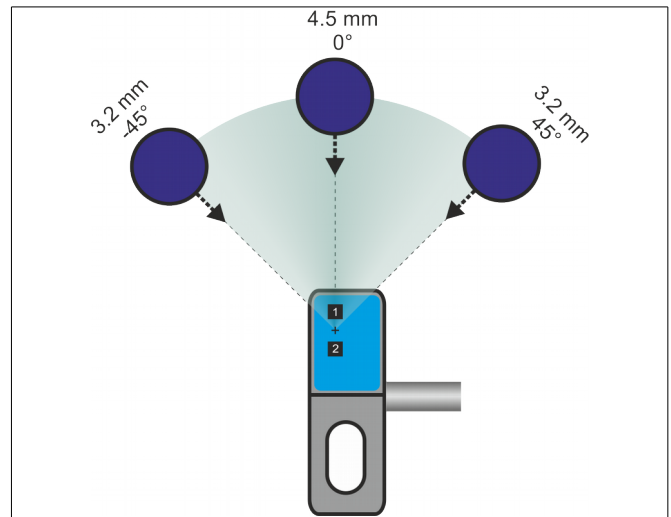

Figure 34: Arrangement of prev. position sensor and magnet lever.

If the traveling distance of the magnet between the positions *pawl-on-pawl* and *end stop* cannot be extended to 3 mm (prev. sensor: 4.5 mm), then the angle between magnet distance and position sensor can be increased up to ±45° instead.

The setting of the position sensor can be verified with the “*indicator*” (or “*func.*”) LED of the CTS box.

For this purpose, the ignition is turned on without starting the engine.

In idle position of the position sensor, the magnet must be distant at least 1.5 mm from each sensor element. In this case, the green LED “*indicator*” (or “*func.*”) will glow continuously.

Subsequently, the motorbike is upshifted: If the gear shift lever can only be levered to the position *pawl-on-pawl*, then the position sensor must be kept in this position, but the magnet must be twisted until the sensor element *pawl-on-pawl* signals. This is indicated by a fast blinking of the green LED “*indicator*” (or “*func.*”). The *pawl-on-pawl* position may also not be leaving solely with more or less force onto the gear shift lever, but only by rotating the rear wheel concurrently.

If the *end stop* position is reached by rotating the rear wheel, then the green LED “*indicator*” (or “*func.*”) must blink slowly (or glow continuously with older firmware versions).

Adjustment

The position sensor is adjusted as follows: The magnet lever is loosened (under maintaining the distance from 1 to 2 mm to the position sensor) until it is just manually rotatable while it is still participating in the movements of the gear shift lever.

Measurement of the magnet's traveling distance: In idle position, the magnet should have a distance to the sensor element *pawl-on-pawl* of the range from 3 to 5 mm. Then the gear shift lever is set into the *pawl-on-pawl* position (= sensor position A). Then the gear shift lever is set into the *end stop* position (= sensor position B). The distance from sensor position A to B is about 3.0 mm to 4.5 mm (prev. sensor: 3.2 mm to 4.5 mm). Half of this distance is accordingly about 1.5 mm to

2.3 mm (prev. sensor: 1.6 mm to 2.3 mm).

Fixation of the gear shift lever: From here on, the gear shift lever is fixed in end stop position (e. g. with a belt). Then the magnet, coming from the idle position, is rotated, from the position of first recognition of the end stop position (= change of the LED blink frequency from fast to slow), one half further of the distance from A to B. Then the magnet lever is fixated.

Verification: For verification, the gear shift lever is set into end stop position. Thereby the change from slow to fast blinking should be after about half of the distance from A to B. Then the gear shift lever is set into pawl-on-pawl position. Here, the LED must always blink fast and it must not, in any case, blink slowly, independent from the force of the gear shift lever. Thereby the springs of the force sensor are pressed until they blockade.

In case that it is difficult to rotate the magnet lever, the position sensor can also be adjusted by moving it inside its slotted hole. This requires that the magnet lever is already roughly adjusted, meaning that in end stop position, the magnet should already be moved 5 mm (prev. sensor: 2 mm) inside the blue field of the position sensor.

New Position Sensor

The cable of the new position sensor is gray instead of black. It has a diameter of 3.3 mm instead of 4.3 mm, and is connected at the other side of the sensor. **The distance between the hall sensor elements of the new sensor is 3 mm instead of 4.5 mm.**

The cable wires of the position sensor are as follows:

Pin	Description	Prev. Sensor	New Sensor
R1	Supply voltage	red	white
R2	Ground	brown	brown
R3	Signal	black	green
R4	CTS off-switch		

In case of changing from prev. positions sensor to the new position sensor, the magnet must be positioned 2.5 mm further into the blue region.

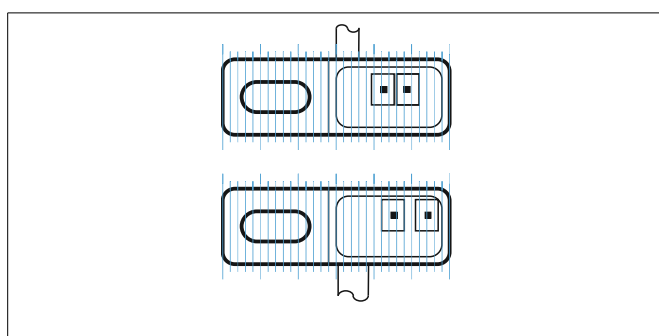

Figure 35: New position sensor (top) and prev. position sensor (bottom) with scale 1:1.

Appendix 3: Older Pos. Sensor

The older position sensor detects the progress of the upshifting operation. Three sensor elements are used for this purpose. Thereby the two sensor elements *pawl-on-pawl* and *end stop* are most important. The sensor is mounted at the crankcase, and a magnet, which is fixed onto a lever to the gear shift lever shaft, swings over the blue area of the sensor. The distance between magnet and sensor should be less than 1.5 mm, at which the axial slackness of the gear shift lever shaft should not cause a contact of the magnet with the sensor.

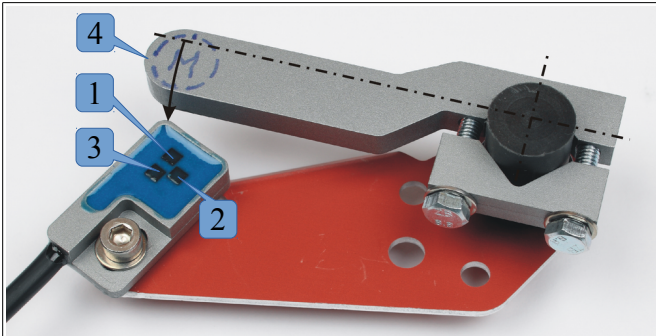

Figure 36: Older position sensor and magnet lever.

1. Sensor element *pawl-on-pawl*
2. Sensor element *pawls are partially in contact*
3. Sensor element *end stop*
4. Magnet (glued from behind)

The sensor elements are dependent on a magnetic field, and signal as soon as the edge of the magnet approximates the center of the respective sensor element to about 1.5 mm.

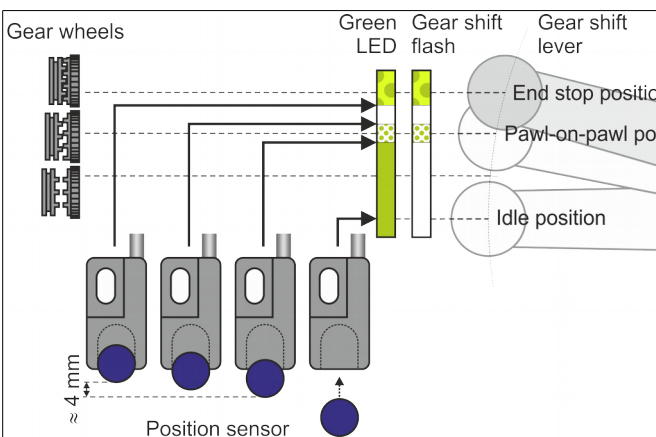

Figure 37: Sensor positions.

For a correct functioning of the sensor, it is important that the respective sensor elements signal in the right order. Therefore, while upshifting, the magnet has to approximate the sensor with an angle from preferably 0° to maximal 60° (see also green valid area of Figure 38).

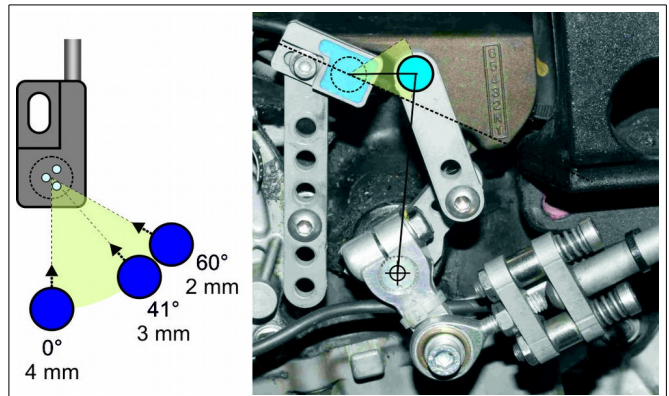

Figure 38: Arrangement of older position sensor and magnet lever.

If the traveling distance of the magnet between the positions *pawl-on-pawl* and *end stop* cannot be extended to the range from 3 mm to 4 mm (but only to minimal 2 mm), then the angle between magnet distance and sensor can be increased up to 60° instead.

The setting of the sensor can be verified with the “indicator” (or “func.”) LED of the CTS box.

For this purpose, the ignition is turned on without starting the engine.

In idle position of the sensor, the magnet must be distant at least 1.5 mm from each sensor element. In this case, the green LED “indicator” (or “func.”) will glow continuously.

Subsequently, the motorbike is upshifted: If the gear shift lever can only be levered to the position *pawl-on-pawl*, then the sensor must be kept in this position, but the magnet must be twisted until the sensor element *pawl-on-pawl* signals. This is indicated by a fast blinking of the green LED “indicator” (or “func.”). The *pawl-on-pawl* position may also not be leaving solely with more or less force onto the gear shift lever, but only by rotating the rear wheel concurrently.

If the *end stop* position is reached by rotating the rear wheel, then the green LED “indicator” (or “func.”) must blink slowly (or glow continuously with older firmware versions).

Only for older CTS firmware versions: With slightly going back of the gear shift lever, the position *pawls are partially in contact* can be verified. When this position is reached, the green LED “indicator” (or “func.”) shuts off completely. This position is unimportant and is merely useful for a simple setup of the other both positions.

For certain motorbikes the arrangement of older position sensor and magnet lever is not suitable. For this case, a special version of the older position sensor is available, which is turned 90° to the left. The letter L is imprinted on the sensor to distinguish the L-version from the standard version.

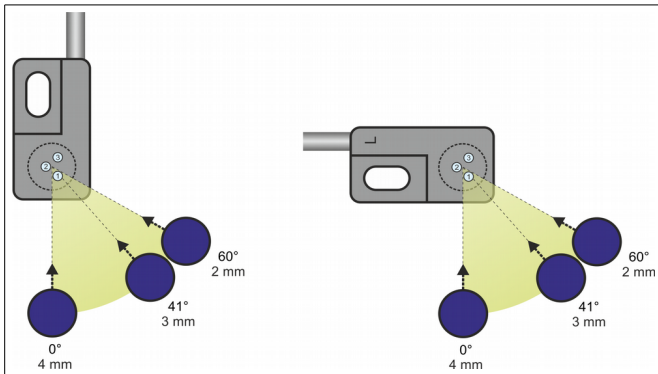

Figure 39: Standard version of the older position sensor (left); L-version of the position sensor (right);

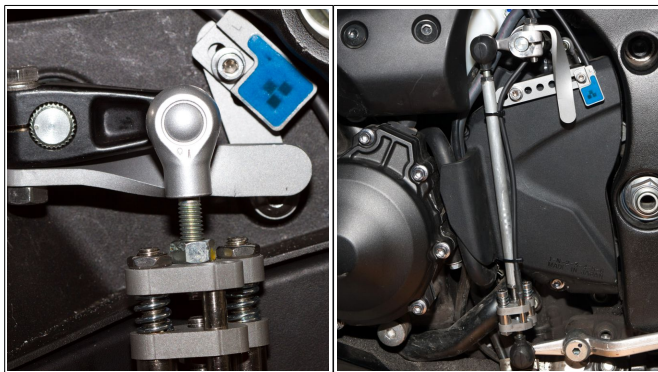

Figure 40: L-version of the older position sensor – Honda SC59 ABS with standard shifting (left); Yamaha RN22 with standard shifting (right);

Position Sensor Holder



Figure 41: Position sensor holder – Standard holder (left), Holder for Honda SC59 (middle), Holder for Honda SC57 (right).

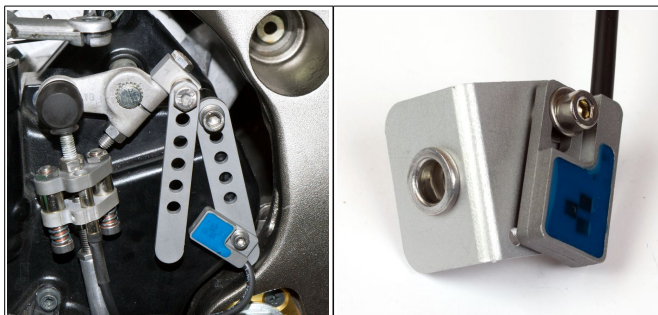

Figure 42: Suzuki K9 with inverted shifting (left); position sensor holder for Yamaha RN19 (right);

Arrangements



Figure 43: Wrong arrangements – the sensor element pawls are partially in contact signals first (left); the sensor element end stop signals first (right);

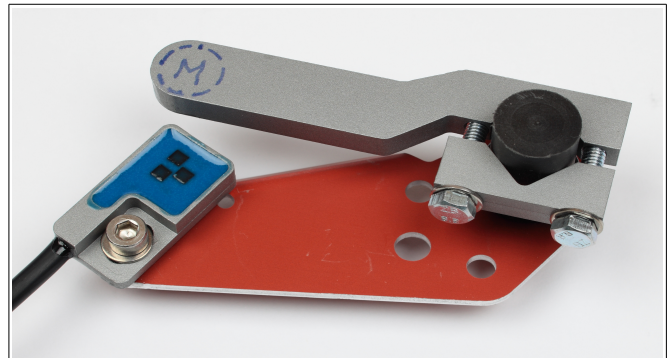

Figure 44: Correct arrangement – idle position.

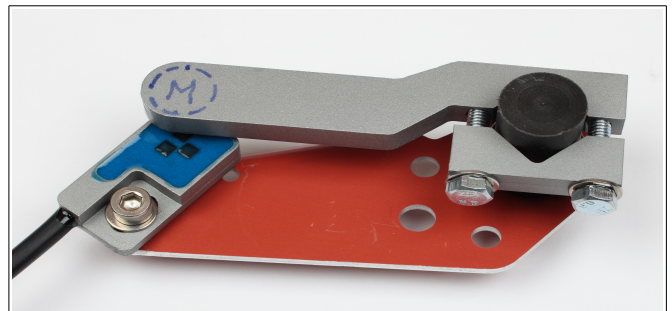

Figure 45: Correct arrangement – pawl-on-pawl position.

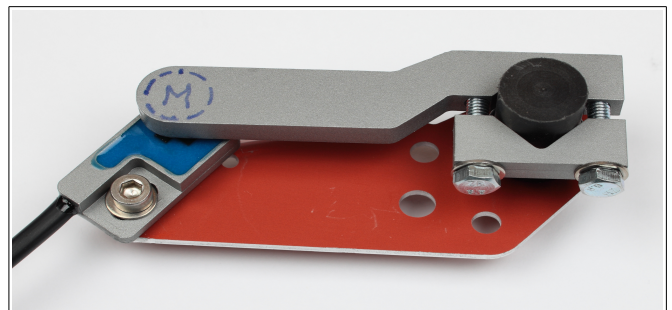

Figure 46: Correct arrangement – End stop position.